

## Standard Flush Glaze Systems

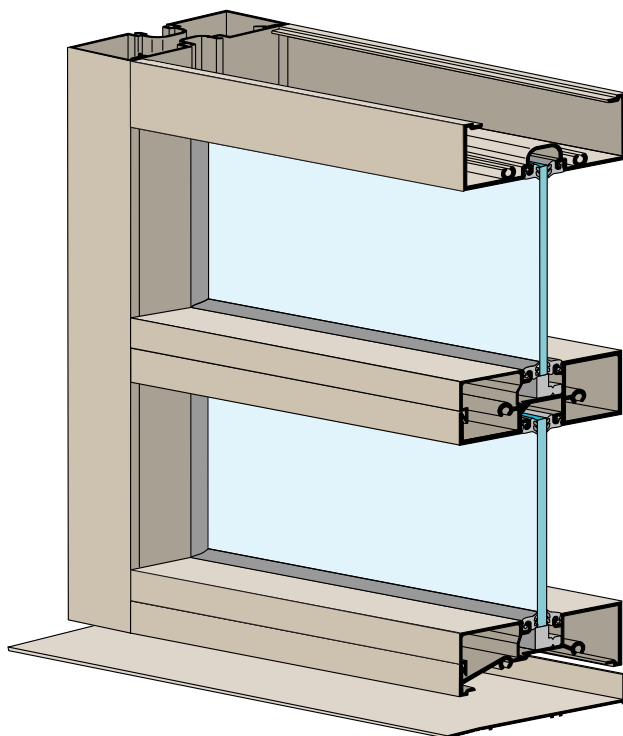

Vistawall offers a complete line of storefront framing systems to meet virtually any application and condition. The Series 1000 is 1 3/4" x 4" and the Series 2000 is 1 3/4" x 4 1/2". Both are designed for 1/4" glazing but are easily adapted to 3/16" or 5/16" infills. The Series 3000 (2" x 4 1/2") is designed for 1" but is adaptable to many different infills ranging from 1/4" to 1 1/8".

Features:

- Three different assembly methods: Screw Spline, Shear Block, and Stacking
- Installation manuals
- Tested by independent laboratories:
  - Air Infiltration: <.06 allowable at 6.24 PSF
  - Water Resistance: 9PSF
- Door framing components
- Sidelite bases to match door bottom rails
- Multiple corner post configurations
- Adjustable and 135° mullions
- Anodized or painted finishes

For more information on how Vistawall can meet or exceed your design ideas, call your local sales representative

Vistawall locations:

**Headquarters**

P.O. Box 629, Terrell, TX 75160

972-551-6100

[www.vistawall.com](http://www.vistawall.com)

Atlanta, GA

Chicago, IL

Cincinnati, OH

Cleveland, OH

Dallas, TX

Denver, CO.

Houston, TX

Las Vegas, NV

Los Angeles, CA

Modesto, CA

Newnan, GA

San Francisco, CA

Seattle, WA

St. Louis, MO

Tampa, FL

Terrell, TX

Warwick, RI

Washington, DC

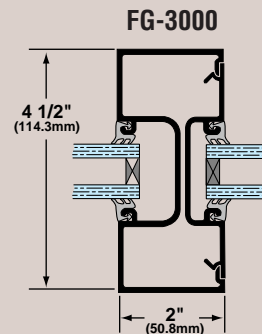
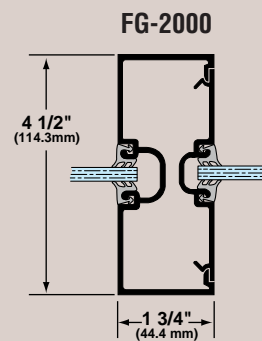
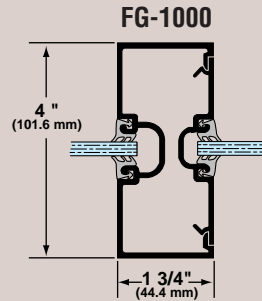

# Standard Flush Glaze Systems

SCREW SPLINE ASSEMBLY

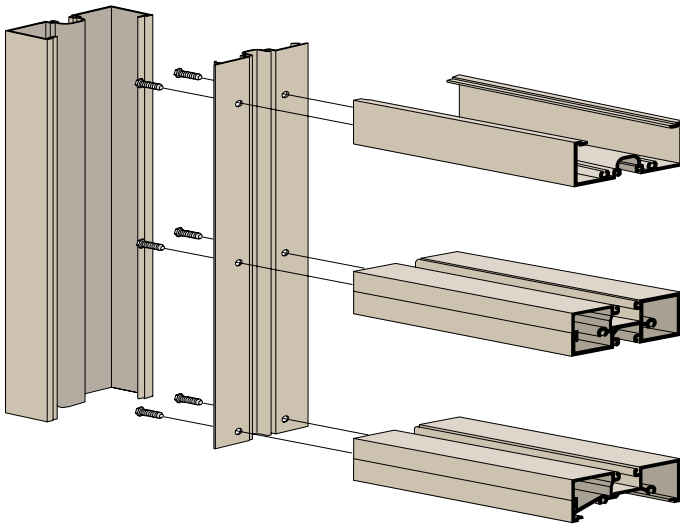

SHEAR BLOCK ASSEMBLY

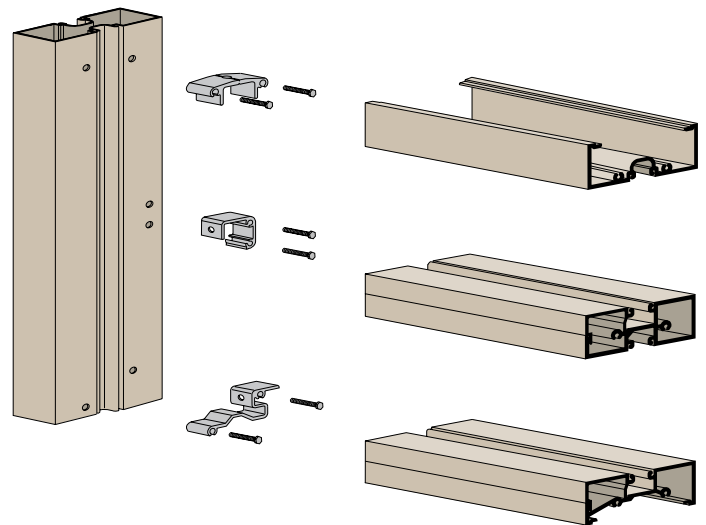

STACK ASSEMBLY

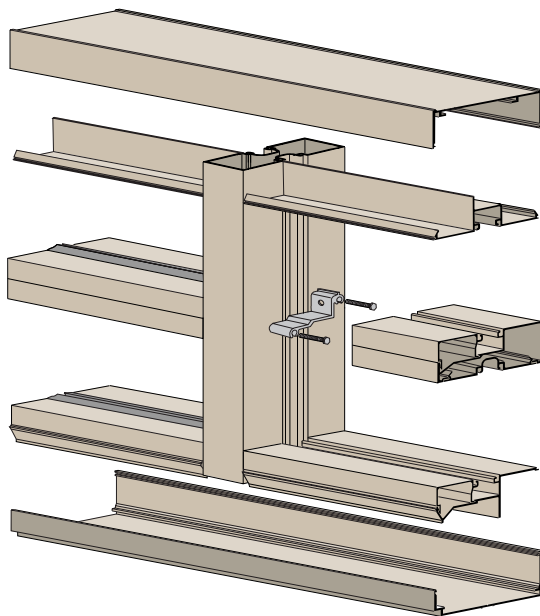

135° CORNER

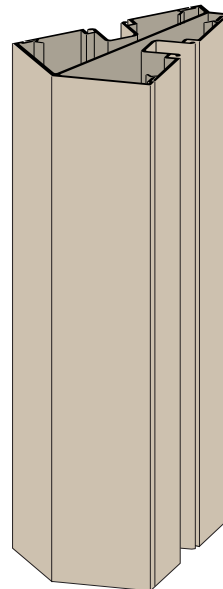

ADJUSTABLE MULLION

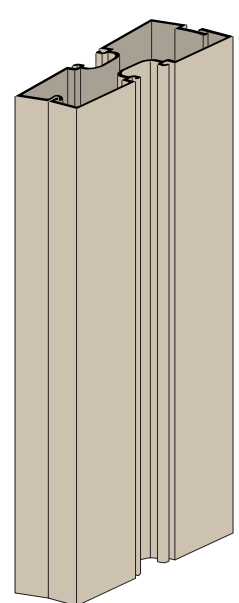

THE VISTAWALL GROUP  
BUTLER MANUFACTURING COMPANY